



DESIGNED FOR EFFICIENCY

**5,000 – 6,500 LB. CAPACITY
ELECTRIC PNEUMATIC TIRE LIFT TRUCKS**





BUILT FOR TH

Made For Your Business

The Cat® 2EPC5000-2EP6500 series of electric pneumatic tire lift trucks offers maximum performance for a wide range of applications.

Designed to thrive in tough environments, this series features all the benefits of an electric forklift combined with the strength and power you'd expect from internal combustion engines.



E LONG HAUL

KEY ADVANTAGES:

- **Lower cost of ownership** – On average, the overall life cycle operating costs for electric forklifts are one quarter of the cost of IC lift trucks*. What does this mean for your business? A greater cost savings over the long run without sacrificing power or performance.
- **Longer run times** – Up to two shifts on one battery charge in most applications.
- **Flexible use, indoors and out** – This series is designed for both indoor and outdoor use with the ability to lift up to 6,500 lbs.
- **Low maintenance** – Sealed components provide added protection from dust, debris and moisture, resulting in a lift truck that's built to operate in even the most demanding applications.
- **Zero fuel costs, zero emissions** – Electric lift trucks offer a cleaner working environment, and with no fuel costs, you'll see the savings add up - today and into the future.

THE ELECTRIC BENEFIT

See how an electric lift truck can save you more over the long run:
www.cat-lift.com

* Based on a five-year life cycle.

COMFORT, FROM THE FIRST HOUR TO THE LAST

Smooth Handling, Greater Control

Built to tackle demanding applications both indoors and out, the 2EPC5000-2EP6500 series is equipped to keep your operators comfortable and in control, shift after shift.

TOTAL CONTROL

Your operators will enjoy this lift truck's high degree of control and its quiet, comfortable ride.

- **Fingertip hydraulic controls** – integrated directly into the armrest, these controls deliver low-effort handling and precise control. For added convenience, the travel direction switch and horn are incorporated into the armrest for one-touch access during operation.
- **One-touch / two-axis armrest** – allows up-and-down and fore-and-aft adjustment plus the ability to adjust the surface angle to optimize comfort for operators and minimize fatigue.
- **Storage compartment** – includes USB power port, useful for charging mobile devices, and is large enough to hold small tools, writing instruments, keys and other personal items.
- **Advanced Curve Control technology** – automatically reduces travel speed when turning, providing added security for the operator and the load.
- **Operator presence detection system** – automatically disengages the hydraulic controls and sets the parking brake when the operator is not in the proper operating position.



THREE TYPES OF PILOTS:

Depending on operator preference, each of these hydraulic controls is available to help maximize productivity.



Fingertip Control (Standard)



Joystick Control (Optional)



Mini-Lever Control (Optional)

2-way adjustable armrest
A one-touch adjustment puts control at your fingertips.

Fully-adjustable steering column
For ample leg room.

Fully-floating operator cabin
Offers four suspension points to increase comfort and reduce fatigue

Three-way, adjustable full-suspension seat
Comfort and a smooth ride.

Operator Presence Detection System
Disengages the hydraulic controls and applies the parking brake when the operator is not properly seated

Anti-cinch seat belt
Effortless reverse travel.

What Makes A Comfortable Ride

Operators can work long shifts comfortably in a wide range of applications due to the lift truck's ergonomic design. Less fatigue means more productivity throughout the shift.

EXCEPTIONAL EFFICIENCY

To Get The Job Done

Cat lift trucks are designed to help you get the most out of your work day. From enhanced energy efficiency for greater uptime to premium performance levels, your operators will effectively move more per shift, every day.

SUPERIOR PERFORMANCE

Equipped with powerful 3-phase AC motors, the 2EPC5000-2EP6500 series boasts outstanding acceleration and impressive top speeds.

The truck's intelligent design and compact component layout also result in:

- Excellent performance on ramps and grades, providing a smooth transition from indoors to out
- Greater torque – even at a lower speed, with no torque gaps and no speed loss
- Top travel speed over 10 mph can be adjusted to meet facility speed requirements

RELIABLE MOTORS

Closed electric motors allow these lift trucks to operate in environments that previously only IC trucks could handle.

- **Fully-enclosed motor** – A motor with fewer parts means less maintenance needed. The motor's compact design and proximity to other components provides increased energy efficiency, helping you get more out of each shift.
- **Ingress protected** – The truck's sealed systems provide better protection against dust, moisture and other debris to take on your toughest applications.
 - IP54-rated motors
 - IP56-rated connectors

POWER TO EXCEL - IN ALL APPLICATIONS

Featuring excellent performance levels, these lift trucks are built to excel in industries where IC lift trucks were once the only option.

- Optional enclosed cabin provides added durability and comfort when operating in wet, cold or extreme conditions
- Durable design and sealed components also provide added protection when working in severe temperatures or sensitive environments



OPTIONS TO INCREASE YOUR PRODUCTIVITY ⁷



Comfort (closed) cabin



Access authorization



Joystick unitized control

Enhance Your Operation

Additional options are also available to further customize the lift truck for your business.



Advanced ergo seat



Snap-Fit battery extraction



Mini-lever hydraulic control

Comfort (closed) cabin

Helps protect operators from adverse weather conditions. This cabin has additional options to further boost productivity in even the harshest environments.

Access authorization

Allows operator access via keypad with assigned user codes.

Advanced ergo seat

This five-way adjustable seat can improve operator comfort when driving over long distances.

Hydraulic accumulator

Provides additional cushioning when carrying heavy loads.

Dual solid pneumatic tires

Better distributes floor loading weight on unpaved surfaces when carrying a load.



15° swivel seat



Light packages



Hydraulic accumulator

Cold storage or Tropics modification

Equips the lift truck with special fluids and conditioning for optimal performance in cold or humid storage environments.

Travel speed reduction

Limits the top travel speed based on workplace preferences.



Electric heater



Cold storage / Tropics modification



Raised operator cab (for special applications)

INCREASE YOUR POTENTIAL WITH LITHIUM-ION

The lithium-ion battery package provides the highest performing battery solution –

- High performance batteries that are synchronized with the lift truck and charger for optimal energy efficiency
- No maintenance requirements and a longer service life mean each truck offers more daily use, increased throughput and reliable 24/7 performance.
- No more battery change-outs, watering, and degassing areas
- Maximize truck productivity through opportunity charging that can be interrupted anytime
- 5-year battery warranty included.

*Ask your local dealer for a complete list of options.



Local service and support



Genuine OEM parts



Custom financing packages

MORE CONFIDENCE





Factory warranty for added protection



Local Support You Can Count On

A Cat lift truck purchase connects you to a variety of material handling solutions, including world-class service and support from your local, trusted dealer. With factory-trained service technicians, a diverse parts inventory and a broad selection of service options, your local dealer can help you lower costs, enhance productivity and more efficiently manage your business.

FINANCING MADE SIMPLE

Financing your next Cat lift truck is easy with our wide range of flexible leasing and purchasing options. Whether you want to finance or lease, your local Cat lift truck dealer can help customize a package for your business.

WHEN EVERY PART COUNTS

When buying from your local Cat lift truck dealer, you can rest assured that your genuine OEM parts are manufactured to meet original equipment criteria. Additionally, all Cat lift truck OEM parts come with a six-month, unlimited-hours warranty.

When speed is critical, our Parts Fast Or Parts Free Guarantee* ensures next-business-day delivery of all Cat lift trucks parts, or they're free, including freight. If your part doesn't come in by the next business day, we pay for it.

STANDING BEHIND OUR PRODUCTS

We deliver peace of mind by helping your lift trucks stay on the job. Every new Cat lift truck is covered by a 1-year / 2,000-hours warranty that includes parts and labor, as well as components and systems. With our standard 2-year / 4,000-hours extended powertrain warranty, you'll have the confidence that only comes from owning a Cat lift truck.

* At dealer's location.

† Programs may be subject to change without notice and may vary by region. Please ask your local Cat lift truck dealer for complete terms and conditions.

Specifications

Characteristics				2EPC5000		2EP5000		2EPC6000				
1	Capacity	at rated load center	lb	kg	4,928	2,500	4,928	2,500	5,917	3,000		
2		at load center – distance	in	mm	24	500	24	500	24	500		
3	Power	diesel, gasoline, LP gas, electric			electric		electric		electric			
4	Tire type	cushion, solid pneumatic			solid pneumatic		solid pneumatic		solid pneumatic			
5	Wheels (x=driven)	number front / rear			2x / 2		2x / 2		2x / 2			
Dimensions				2EPC5000		2EP5000		2EPC6000				
11	Lift with standard two-stage mast	maximum fork height	in	mm	122	3,100	122	3,100	122	3,100		
12		free fork height	in	mm	5.9	150	5.9	150	5.9	150		
13	Forks	thickness x length x width	in	mm	1.6x4.7x43	40x120x1,100	1.6x4.7x43	40x120x1,100	1.8x4.9x43	45x125x1,100		
	Fork spacing	out-to-out minimum / maximum	in	mm	13.25 / 40.25	335 / 1,022	13.25 / 40.25	335 / 1,022	13.75 / 40.5	349 / 1,028		
14	Tilt	forward / backward	deg		6° / 8°		6° / 8°		6° / 8°			
15	Overall dimensions	length to fork face	in	mm	90.4	2,295	96.1	2,440	90.6	2,300		
16		width	standard	in	mm	47.2	1,198	47.2	1,198	47.2	1,198	
			w/ wide stance drive wheels	in	mm	N/A		N/A		51.2	1,300	
17		height	with lowered mast	in	mm	88.2	2,240	88.2	2,240	88.2	2,240	
18	seat height to SIP		in	mm	46.9	1,190	46.9	1,190	46.9	1,190		
19	to top of overhead guard		in	mm	88.2	2,240	88.2	2,240	88.2	2,240		
20	with extended mast		in	mm	170	4,320	170	4,320	174	4,430		
21	Minimum outside turning radius	in		mm	78.7	2,000	84.7	2,150	78.7	2,000		
22	Load moment constant	in		mm	16.7	425	16.7	425	16.9	430		
23	Minimum aisle - 90° stack – zero clearance without load	in		mm	95.5	2,425	101.4	2,575	95.7	2,430		
Performance				2EPC5000		2EP5000		2EPC6000				
24	Speeds	travel speed	loaded / empty	mph	km/h	10.0 / 10.6	16.0 / 17.0	10.0 / 10.6	16.0 / 17.0	10.0 / 10.6	16.0 / 17.0	
		lift speed	loaded / empty	fpm	m/s	84.7 / 108.3	0.43 / 0.55	84.7 / 108.3	0.43 / 0.55	78.7 / 108.3	0.40 / 0.55	
		lowering speed	loaded / empty	fpm	m/s	114.2 / 114.2	0.58 / 0.58	114.2 / 114.2	0.58 / 0.58	114.2 / 114.2	0.58 / 0.58	
27	Drawbar pull (max.)	60 min. rating	loaded / empty	lb-f	N	809 / 899	3,600 / 4,000	787 / 877	3,500 / 3,900	1,012 / 1,124	4,500 / 5,000	
		5 min. rating	loaded / empty	lb-f	N	2,810 / 2,923	12,500 / 13,000	2,810 / 2,923	12,500 / 13,000	3,147 / 3,260	14,000 / 14,500	
28	Gradeability	maximum gradeability	loaded / empty	%		17 / 25		17 / 25		15 / 23		
Weight				2EPC5000		2EP5000		2EPC6000				
29	Empty	with minimum weight battery		lb	kg	10,472	4,750	10,311	4,677	11,530	5,230	
30	Axle load	with rated load	front	lb	kg	14,191	6,437	14,321	6,496	16,152	7,327	
			rear	lb	kg	1,793	813	1,502	681	1,992	903	
		without load	front	lb	kg	5,443	2,469	5,858	2,657	5,558	2,521	
			rear	lb	kg	5,029	2,281	4,453	2,020	5,950	2,699	
Chassis				2EPC5000		2EP5000		2EPC6000				
31	Tire size	front, standard solid pneumatic tires			225 / 75-10		225 / 75-10		250/60-12			
		rear solid pneumatic tires			180/70-8		180/70-8		200/50-10			
32	Wheelbase	in		mm	62.0	1,575	67.7	1,720	62.0	1,575		
33	Tread width	front, standard solid pneumatic tires			in	mm	39.0	990	37.4	950		
		rear solid pneumatic tires			in	mm	37.0	940	37.0	940		
35	Ground clearance	at lowest point at mast			in	mm	4.7	120	4.7	120		
		at center of wheelbase			in	mm	5.3	135	5.3	135		
37	Brakes	service	type		mechanical		mechanical		mechanical			
		parking	type		electric		electric		electric			
Powertrain				2EPC5000		2EP5000		2EPC6000				
39	Battery	dimensions (length x width x height)			in		27.99x40.47x30.87		33.66x40.47x30.87		27.99x40.47x30.87	
		maximum capacity at 6 hr. discharge rate			Ah	kWh	700	54.4	700	54.4	700	54.4
		weight, minimum / maximum			lb	kg	3,263 / 4,037	1,480 / 1,831	3,902 / 4,436	1,770 / 2,012	3,263 / 4,037	1,480 / 1,831
42	Motors	traction output (60 min. rating)			HP	kW	16.1	12.0	16.1	12.0	16.1	12.0
		lift output (15% rating)			HP	kW	24.8	18.5	24.8	18.5	24.8	18.5
44	Controls	drive	type		impulse / AC		impulse / AC		impulse / AC			
		hydraulic	type		AC		AC		AC			
46	Flow rate for attachments	gpm		lpm	6.6	25	6.6	25	6.6	25		
47	Relief pressure	for attachments at auxiliary			psi	bar	2,900	200	2,900	200		
48	Noise level	mean value at operator's ear			dB(A)		70		70			

NOTE: Dimensions represent maximum battery size, not compartment size. These specifications assume the use of drive axles, tires and tilt angles specified. Any modification to specifications, or any other combination of specifications made after the shipment of the truck, requires prior written approval from Mitsubishi Caterpillar Forklift America Inc. (MCFA). (See ANSI/ITSDF B56.1.) Also be advised that overall operating visibility may be affected by the mast configuration and mast options of your forklift truck. Therefore, you may need to add ancillary (auxiliary) devices or modify your operating practices. Consult your dealer for further information.

	2EP6000		2EP6500	
1	5,917	3,000	6,608	3,000
2	24	500	24	600
3	electric		electric	
4	solid pneumatic		solid pneumatic	
5	2x / 2		2x / 2	

	2EP6000		2EP6500	
11	122	3,100	122	3,100
12	5.9	150	5.9	150
13	1.8x4.9x43 13.75 / 40.5	45x125x1,100 349 / 1,028	2.0x4.9x45 13.75 / 40.5	50x125x1,150 349 / 1,028
14	6° / 8°		6° / 8°	
15	96.3	2,445	96.5	2,450
16	47.2	1,198	51.2	1,300
17	51.2	1,300	N/A	
18	88.2	2,240	88.2	2,240
19	46.9	1,190	46.9	1,190
20	88.2	2,240	88.2	2,240
21	174	4,430	174	4,430
22	84.7	2,150	84.7	2,150
23	16.9	430	16.9	430
23	101.6	2,580	101.6	2,580

	2EP6000		2EP6500	
24	10.0 / 10.6	16.0 / 170	10.0 / 10.6	16.0 / 170
25	78.7 / 108.3	0.40 / 0.55	78.7 / 108.3	0.40 / 0.55
26	114.2 / 114.2	0.58 / 0.58	114.2 / 114.2	0.58 / 0.58
27	1,012 / 1,124 3,147 / 3,260	4,500 / 5,000 14,000 / 14,500	1,012 / 1,124 3,147 / 3,260	4,500 / 5,000 14,000 / 14,500
28	15 / 23		15 / 23	

	2EP6000		2EP6500	
29	11,303	5,127	11,876	5,387
30	16,086	7,297	16,462	7,467
30	1,831	830	2,005	910
30	5,846	2,652	5,876	2,665
30	5,457	2,475	5,985	2,715

	2EP6000		2EP6500	
31	250/60-12		315/45-12	
31	180/70-8		200/50-10	
32	67.7	1,720	67.7	1,720
33	37.4	950	39.4	1,000
34	37.0	940	37.0	940
35	4.7	120	4.7	120
36	5.3	135	5.3	135

37	mechanical		mechanical	
38	electric		electric	

	2EP6000		2EP6500	
39	33.66x40.47x30.87		33.66x40.47x30.87	
40	700	54.4	700	54.4
41	3,902 / 4,436	1,770 / 2,012	3,902 / 4,436	1,770 / 2,012
42	16.1	12.0	16.1	12.0
43	24.8	18.5	24.8	18.5
44	impulse / AC		impulse / AC	
45	AC		AC	
46	6.6	25	6.6	25
47	2,900	200	2,900	200
48	70		70	

Call-out numbers shown in diagram correspond to the first column of the specifications chart.

2EPC5000-2EP6500

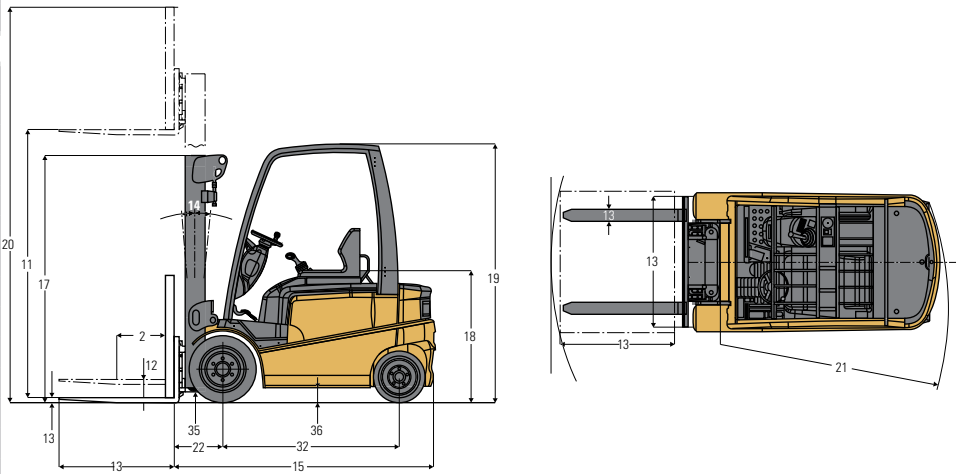

Performance			2EPC5000	2EP5000	2EPC6000	2EP6000	2EP6500
High Performance Configurations							
Speeds	travel speed	loaded	mph km/h	11.8 19.0	11.8 19.0	11.8 19.0	11.8 19.0
		empty	mph km/h	12.4 20.0	12.4 20.0	12.4 20.0	12.4 20.0
	lift speed	loaded	fpm m/s	94.5 0.48	94.5 0.48	84.7 0.43	84.7 0.43
		empty	fpm m/s	118.1 0.60	118.1 0.60	118.1 0.60	118.1 0.60
	lowering speed	loaded	fpm m/s	114.2 0.58	114.2 0.58	114.2 0.58	114.2 0.58
		empty	fpm m/s	114.2 0.58	114.2 0.58	114.2 0.58	114.2 0.58
Drawbar pull (maximum)	60 min. rating	loaded	lb-f N	1,147 5,100	1,102 4,900	1,124 5,000	1,124 5,000
		empty	lb-f N	1,259 5,600	1,237 5,500	1,304 5,800	1,304 5,800
	5 min. rating	loaded	lb-f N	3,597 16,000	3,597 16,000	3,530 15,700	3,530 15,700
		empty	lb-f N	3,664 16,300	3,664 16,300	3,597 16,000	3,597 16,000
Gradeability	maximum gradeability	loaded	%	19	19	17	18
		empty	%	27	27	25	26
Motors	traction output (60 min. rating)	HP kW	20.1 15.0	20.1 15.0	20.1 15.0	20.1 15.0	
	lift output (15% rating)	HP kW	29.5 22.0	29.5 22.0	29.5 22.0	29.5 22.0	

Safety Standards

These trucks meet American National Standards Institute/ Industrial Truck Standards Development Foundation, ANSI/ITSDF B56.1. Users should be aware of, and adhere to, applicable codes and regulations regarding operator training, use, operation and maintenance of powered industrial trucks, including:

- ANSI/ITSDF B56.1.
- NFPA 505, fire safety standard for powered industrial trucks – type designations, areas of use, maintenance, and operation.
- Occupational Safety and Health Administration (OSHA) regulations that may apply.

Specifications, equipment, technical data, photos and illustrations based on information at time of printing and subject to change without notice. Some products may be shown with optional equipment.



Your Cat lift truck dealer can provide additional options and features to specialize your lift truck for your unique application. Operator training and custom financing programs are also available to help find the right fit for your business.

Helping move businesses forward – that's how we're built.

1-800-CAT-LIFT | www.mcfa.com/cat

© 2019 MCFA. All Rights Reserved. CAT, CATERPILLAR, their respective logos, "Caterpillar Yellow," the "Power Edge" trade dress as well as corporate and product identity used herein, are trademarks of Caterpillar and may not be used without permission. All registered trademarks are the property of their respective owners.

Some products may be shown with optional equipment.

CECM0205-01

09/19

