

3,000-5,000lb Mast

Type	Model	Lifting Height	Lowered Height	Overall Height		Free Lifting Height		Tilting Range		Capacity			
				With Backrest	Without Backrest	With Backrest	Without Backrest	Forward	Backward	Load Center at 24"			
				in	in	in	in	deg	deg	3000lbs	3500lbs	4000lbs	5000lbs
Limited Free Lift 2 Stage Mast	M270	106	72	144	127	6.3	6.3	5	5	3000	3500	4000	5000
	M300	118	78	156	139	6.3	6.3	5	5	3000	3500	4000	5000
	M330	130	84	168	151	6.3	6.3	5	5	3000	3500	4000	5000
	M360	142	92	179	163	6.3	6.3	5	5	3000	3500	4000	5000
	M400	157	102	195	179	6.3	6.3	5	5	3000	3500	4000	5000
Full Free Lift 2 Stage Mast	M430	169	107	207	190	6.3	6.3	3.5	5	3000	3500	4000	5000
	U270	106	72	144	131	41	44	5	5	3000	3500	4000	5000
	U300	118	78	155	143	41	53	5	5	3000	3500	4000	5000
	U330	130	84	167	154	47	59	5	5	3000	3500	4000	5000
	U360	142	90	179	166	53	65	5	5	3000	3500	4000	5000
Full Free Lift 3 Stage Mast	U400	157	100	195	182	62	75	5	5	3000	3500	4000	5000
	N400	157	74	195	182	37	50	3.5	5	3000	3500	4000	5000
	N430	169	78	206	194	41	53	3.5	5	3000	3500	4000	5000
	N450	177	80	215	202	43	55	3.5	5	3000	3500	4000	4779
	N470	185	83	222	210	46	58	3.5	5	2800	3400	3800	4559
	N480	189	84	227	214	47	59	3.5	5	2800	3400	3800	4559
	N500	197	87	234	221	50	62	3.5	5	2600	3200	3600	4338
	N550	217	94	254	241	56	69	3.5	5	2200	2800	3200	3897
	N600	236	102	273	261	64	77	3.5	5	1800	2400	2800	3456
	N650	256	111	293	280	74	87	3.5	5	1400	2000	2400	3015
N700	276	117	313	300	80	93	3.5	5	1000	1600	2000	2574	

With the sideshifter, subtract 440lbs (200kg). With the integral sideshifter, subtract 220lbs (100kg).

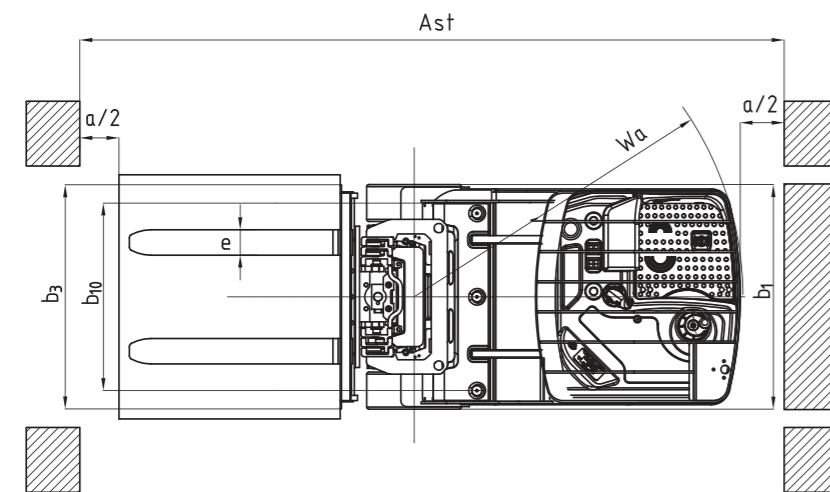
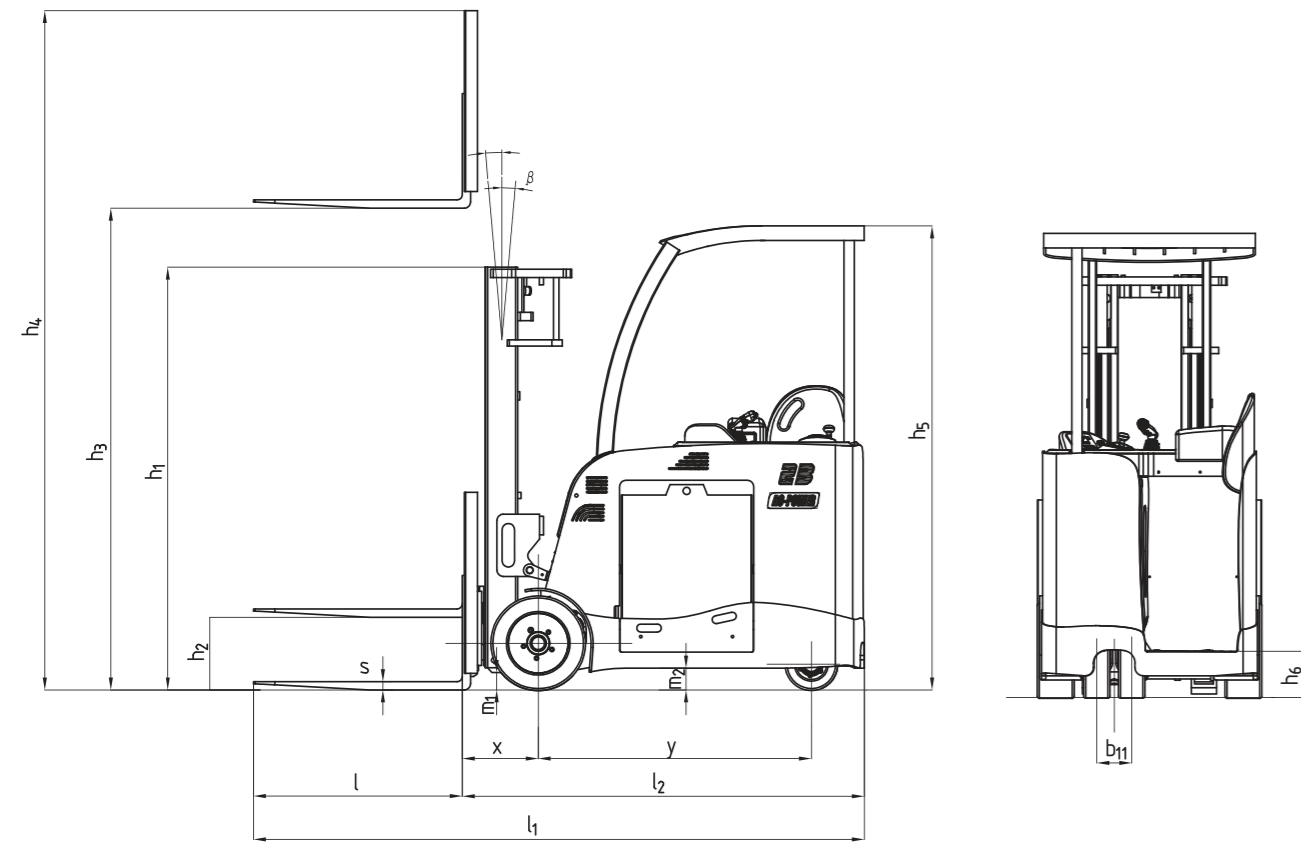

HANGCHA

HC FORKLIFT AMERICA CORPORATION

Company address:
10405-A Granite Street
Charlotte, NC 28273

Toll Free: (888) 652-8395
Phone: (980) 888-8335
Fax: (980) 888-8336

america@hcforklift.com
www.hcforkliftamerica.com



2021 VERSION 1/00P-PR017 2021

HANGCHA GROUP CO., LTD. reserves the right to make any changes without notice concerning colors, equipment, or specifications detailed in this brochure, or to discontinue individual models. The colors of trucks, delivered may differ slightly from those in brochures.



A Series 3-Wheel Stand-up Counterbalanced Lift Truck with Lithium-ion Technology

with capacity of 3,000 to 5,000lbs

Making Material Handling Easier
SINCE 1956



LET THE LITHIUM POWER TAKE OVER



INNOVATIVE SOLUTIONS NEW POWER NOW

Lithium-ion technology (Lithium Iron-Phosphate), was developed jointly by HANGCHA and CATL for use in material handling equipment applications. These innovative and reliable battery cells and modules are manufactured to the highest standard by CATL exclusively for HANGCHA's forklift line.

- / **Battery Technology:** We use square lithium iron phosphate batteries. These are the same type of batteries used in new electric vehicles.
- / **Design:** The module uses a sturdy and lightweight aluminum alloy frame. It is also designed to provide excellent heat dissipation.
- / **Safe and Effective:** Charging efficiency as high as 98% and the thermal runaway temperature is at 600 °C and above.
- / **Adapted to Low Temperatures:** Comes standard with an electrical heating feature, ensuring normal operation in low temperatures.
- / **Quick Charging:** Fully charges in 2 hours.
- / **Efficient:** Can use opportunity charging to allow for continuous use in multi-shift operations.
- / **Long-Lasting:** 4000 charging cycles with a capacity retention greater than 80%.
- / **Maintenance-Free:** Lithium-ion batteries do not require manual maintenance such as watering.
- / **Green and clean:** The batteries are pollution-free, release zero emissions, and are recyclable.

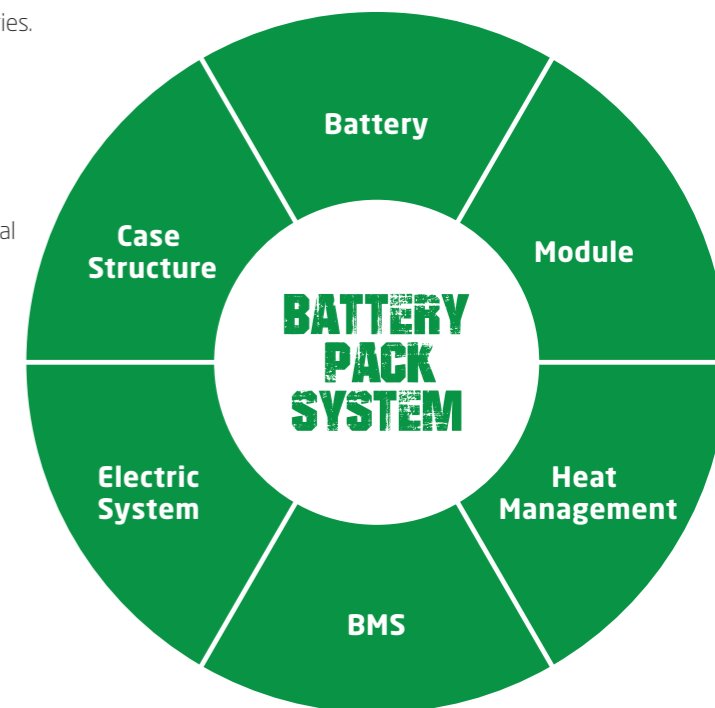

RAPID CHARGING

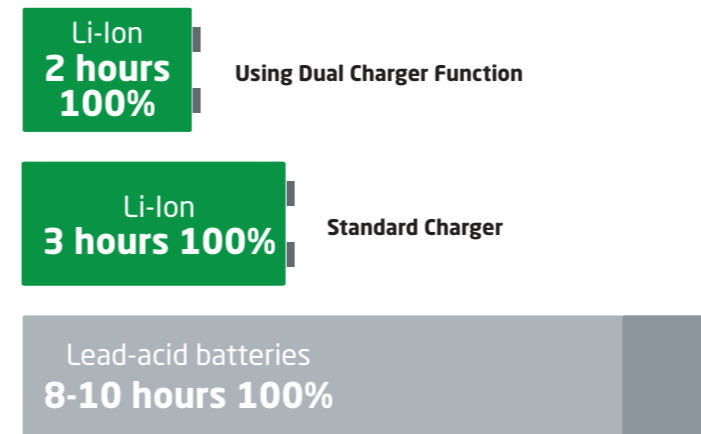

Rapid and opportunity charging ensure continuous availability of material handling equipment

The chargers allow for fast full charging or boost charging (100 % charge in 2 hours). The lithium-ion batteries are maintenance free and do not require a battery change when used in multi-shift operations. Instead, the batteries can be charged during user breaks and shift changes which allows the forklift to continuously run during multi-shift operations.



**Standard Charger
(48V/200Ah)**



HANGCHA PROVIDES UP TO A
10 YEAR OR 20000 HOUR GUARANTEE
ON THE LITHIUM-ION BATTERY PACKS.



**10 YEAR
WARRANTY**

Tough
Reliable
Smart



Appearance

/ The A Series 3-Wheel Stand-Up Counterbalanced Lift Truck is designed to stack and retrieve goods efficiently in narrow aisles and at high lift heights while still maintaining a lifting capacity of up to 5,000lbs. The exterior of this forklift is powder coated in a durable, easy to see, green finish designating it as lithium-ion powered.

Comfort

/ The user operates this forklift while standing in a side stance.
/ The step is low for conveniently getting on and off the forklift.
/ An anti-fatigue floor mat and generous padding for knees, hips, and arms keep operators comfortable over long shifts.
/ The spacious operator compartment provides a comfortable work environment for the operator.

High Performance

/ Thanks to the advanced front dual-drive AC motor, the traveling performance, maneuverability, and operating efficiency are greatly improved.
/ Hangcha's AC hydraulic system provides smooth load handling and precise load placements.
/ The electronic proportional multi-way valve reduces energy consumption.
/ Electric Power Steering provides precise steering control with minimal effort. It also does not encroach into the operator compartment.

Safety

/ Cornering speed control automatically slows the forklift's travel speed while turning to help prevent damage to loads.
/ Operation is easy thanks to the foot-raising brake pedal.
/ The electronic parking brake greatly improves the safety of the truck and the operator.
/ With the pedal sensing system, the truck can be driven only if the operator stands on the pedal. If the operator takes their foot off the pedal, active braking is initiated to prevent an accident.

Reliability

/ The vehicle's frame is robust and reliable thanks to its high-strength steel frame structure.
/ All of the forklift's wires and cables are protected. This greatly improves the reliability of the electrical system.
/ Switches, connectors, instruments, and other key parts are all high-quality products with excellent performance and quality.



The wide view mast provides great visibility. The hydraulic cushioning feature provides confidence and smooth load handling while operating this forklift.



Ergonomic: The truck is designed for maximum operator comfort while traveling forward or backward in a side stance position. The back and elbow supporting cushions provide better support for the operator.



The battery side roll out is a part of the standard configuration.



The intuitive, multifunction control handle is centrally positioned for easy access. The handle offers simultaneous control of the drive, lift, lower, and auxiliary hydraulic functions.



CATL Lithium Iron Phosphate Battery Packs

- / Integrated Battery Management System (BMS) continually monitors energy management and ensures reliable operation.
- / HANGCHA provides these Lithium Iron Phosphate (LiFePO4) battery packs with up to a 10 year or 20,000 hour warranty.
- / See warranty certificate for specific warranty information on the Lithium Iron Phosphate battery packs.

Standard Battery Capacity

Model	FBT15SLi	FBT18SLi	FBT20SLi	FBT23SLi
Battery Capacity (V/Ah) (kW-h)	36V/606Ah 21.82kW-h	36V/606Ah 21.82kW-h	36V/813Ah 29.27kW-h	36V/813Ah 29.27kW-h

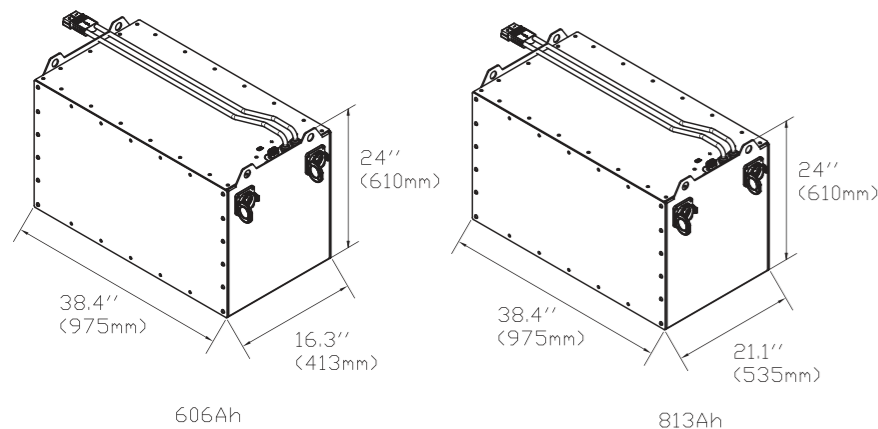

Standard Specification

- / AC Dual Drive Motors
- / AC Pump Motor
- / Multiple Operation Modes
- / Electric Power Steering System
- / Regenerative Braking
- / Electronic Parking Brake
- / Cornering Speed Control
- / Operator Presence Sensing System
- / Shock Absorption Pedal
- / Waist and Elbow Supporting Cushion
- / Multi-Functional Instrument Display
- / Smooth Cushion Tires
- / Emergency Cut Off Switch
- / Integrated Operating Handle
- / Quadruple and Multi-Way Valves
- / 117" Limited Free Lift 2 Stage Mast
- / Electric Horn
- / Cup & File Holder
- / Low Noise Gear Pump
- / Soft landing system
- / Battery Side Extraction Rollers
- / Strobe Light

Options

- / LED Work Lights
- / Blue Safety Light
- / Sideshifter
- / Full Free Lift 2 Stage Mast
- / Full Free Lift 3 Stage Mast
- / Various Fork Lengths
- / Specialty Attachments
- / Widened Load Bracket & Fork Carriage
- / Lower Overhead Guard
- / Charger
- / Freezer
- / Pin & Card Access System
- / 12V Socket
- / USB Charging Output
- / Overhead Fan
- / Fire Extinguisher

A Series 3-Wheel Lithium-ion Stand-up Counterbalanced Lift Truck Specification

		HANGCHA GROUP CO., LTD.					
Distinguishing Marks	1.1	Manufacturer					
		HCFA Model	FBT15SLi	FBT18SLi	FBT20SLi	FBT23SLi	
	1.2	Manufacturers Type Designation	CPDS15-AD4S-1	CPDS18-AD4S-1	CPDS20-AD4S-1	CPDS23-AD4S-1	
	1.4	Operator Type: hand, pedestrian, standing, seated, order-picker	Standing	Standing	Standing	Standing	
	1.5	Load Capacity/Rated Load	Q (lbs)	3000	3500	4000	5000
Weight	1.6	Load Centre Distance	c (in)	24	24	24	24
	1.8	Load Distance, centre of drive axle to fork	x (in)	12.6	12.6	12.8	12.8
	1.9	Wheelbase	y (in)	43.2	45.1	48	51.8
	2.1	Service Weight	lbs	7991	8454	8818	9900
	2.2	Axle Loading, laden front/rear	lbs	10110/881	10997/957	11792/1026	13708/1192
Tires & Chassis	2.3	Axle Loading, unladen front/rear	lbs	4154/3837	4395/4059	4585/4233	5148/4752
	3.1	Tires		Cushion	Cushion	Cushion	Cushion
	3.2	Tire Size, front		18-7-12.125	18-7-12.125	18-7-12.125	18-7-12.125
	3.3	Tire Size, rear		10-5-6.5	10-5-6.5	10-5-6.5	10-5-6.5
	3.5	Wheels, number front rear (x = driven wheels)		2x/2	2x/2	2x/2	2x/2
Dimensions	3.6	Tread, front	ba (in)	35.6	35.6	35.6	35.6
	3.7	Tread, rear	ba1 (in)	6.6	6.6	6.6	6.6
	4.1	Tilt of Mast/Fork Carriage Forward/Backward	Grad	5/5	5/5	5/5	5/5
	4.2	Height, mast lowered	h1 (in)	78	78	78	78
	4.3	Free lift	hz (in)	6.3	6.3	6.3	6.3
	4.4	Lift	hs (in)	118	118	118	118
	4.5	Height, mast extended	hx (in)	144	144	144	144
	4.7	Height of Overhead Guard	hs (in)	87.8	87.8	87.8	87.8
	4.8	Stand Floor Height	ha (in)	8.6	8.6	8.6	8.6
	4.19	Overall Length	l (in)	102.1	103.9	107	110.8
	4.20	Length to Face of Forks	lz (in)	65.8	67.7	70.8	74.6
	4.21	Overall Width	bl (in)	42.6	42.6	42.6	42.6
	4.22	Fork Dimensions	s/e/l (in)	1.37/3.9/36.2	1.37/3.9/36.2	1.57/4.8/36.2	1.57/4.8/36.2
	4.23	Fork Carriage DIN 15 173 --- ISO 2328, class/type A,B		ISO2328 3A	ISO2328 3A	ISO2328 3A	ISO2328 3A
	4.24	Fork-Carriage Width	bs (in)	39.4	39.4	39.4	39.4
Performance Data	4.31	Ground Clearance, laden, below mast	m (in)	3.9	3.9	3.9	3.9
	4.32	Ground Clearance, centre of wheelbase	mc (in)	3.8	3.8	3.8	3.8
	4.33	Aisle Width for Pallets 39" x 47" Crossways	Ast (in)	118.8	120.6	123.8	127.6
	4.34	Aisle Width for Pallets 31.5" x 47" Crossways	Ast (in)	123.6	125.4	128.6	132.4
	4.35	Turning Radius	Wa (in)	53.8	55.7	58.6	62.4
	5.1	Travel Speed, laden/unladen	mph	7.7/8	7.7/8	7.7/8	7.7/8
	5.2	Lift Speed, laden/unladen	fpm	78/110	68/110	62/110	59/110
	5.3	Lowering Speed, laden/unladen	fpm	93/83	93/83	93/83	93/83
	5.7	Gradeability, laden/unladen	%	15/15	15/15	15/15	15/15
	5.8	Max. Gradeability, laden/unladen	%	15/15	15/15	15/15	15/15
Electric Motor	5.9	Acceleration Time, laden/unladen (0-10m)	s	6.1/6	6.1/6	6.1/6	6.1/6
	5.10	Service Brake		Electric	Electric	Electric	Electric
	5.11	Parking Brake		Electric	Electric	Electric	Electric
	6.1	Drive Motor Rating S2 60 min	kW	4.2-2 AC	4.2-2 AC	4.2-2 AC	4.2-2 AC
	6.2	Lift Motor Rating at S3 15%	kW	10AC	10AC	10AC	10AC
	6.4	Battery Voltage, nominal capacity K5	V/Ah	36/606	36/606	36/813	36/813
	6.5	Battery Weight	lbs	617	617	742	742
	6.6	Battery Dimensions	l/b/h(in)	38.4-16.3-24	38.4-16.3-24	38.4-21.1-24	38.4-21.1-24
	6.8	Min. Battery Weight	lbs	573	573	694	694
	6.9	Max. Battery Weight	lbs	648	648	815	815
Additional Data	6.10	Battery Roller Height	in	14.3	14.3	14.3	14.3
	8.1	Manufacturer of Controller		INMOTION	INMOTION	INMOTION	INMOTION
	8.2	Oil Volume for Attachments	l/min	20	20	20	20
8.3	Sound Level at the Driver's Ear According to EN / DIN 12 053	dB (A)	63	63	63	63	