

Part No.501036110002

Rev: B

Mar 2021

# Maintenance Manual

---



GTJZ0408S/0408S/1530S

GTJZ0608S/0608S/1930S

GTJZ0408M/0408M/1532M

GTJZ0608M/0608M/1932M

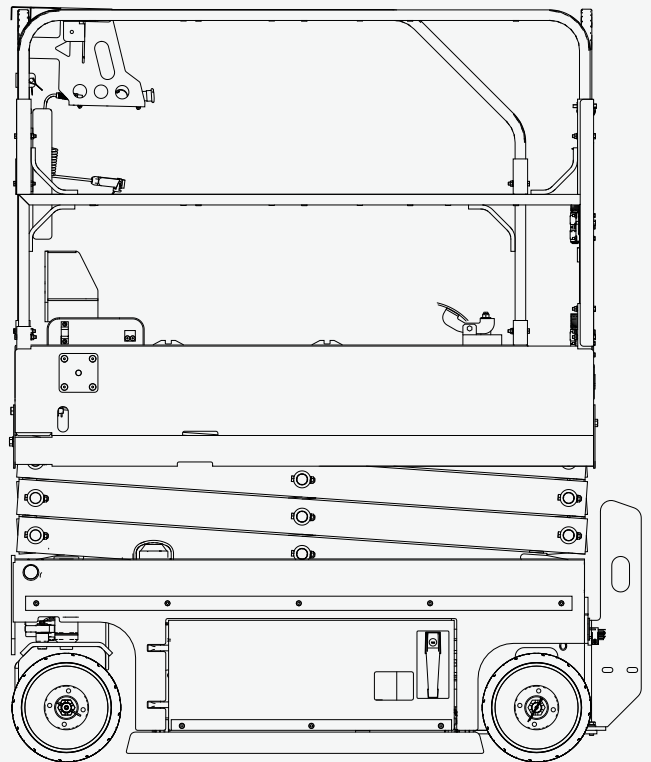

CE  AS/NZS  EAC GB 

**SINOBOOM**

## Manual revision history :

REV	DATE	DESCRIPTION	REMARK
A	Apr 2020	Original issue of the manual	
B	Mar 2021	Manual updated	

### Please contact us:

Website : [www.sinoboom.com](http://www.sinoboom.com)

E-mail : [sales@sinoboom.com](mailto:sales@sinoboom.com)

Sales Tel : 0086-0731-87116222

Service Tel : 0086-0731-87116333

Address : No.128, East Jinzhou Avenue, Ningxiang High-tech Industrial Park, Changsha,  
Hunan, China

Zip Code : 410600

Copyright © Hunan Sinoboom Intelligent Equipment CO.,Ltd. All Rights Reserved

The final interpretation right of this manual belongs to Hunan Sinoboom Intelligent Equipment CO.,Ltd.

# APPLICATION

Use the following table to identify the specific serial number for models included in this manual. Check the model of your machine before consulting the manual, and then use the correct manual according to the serial number of the model. See the nameplate on your machine to identify the model and serial number. (See *Decals/Nameplate Inspection* of the *Operation Manual* for details.)

MODELS	Trade identification		SERIAL NO.
	Metric	Imperial	
GTJZ0408S	GTJZ0408S	1530S	From 0103700150 to present
GTJZ0608S	GTJZ0608S	1930S	From 0103803150 to present
GTJZ0408M	GTJZ0408M	1532M	From 0103500150 to present
GTJZ0608M	GTJZ0608M	1932M	From 0103600550 to present

## NOTE:

- Product model is applied in product nameplate for distinction of products of different main parameters.
- Product trade identification is applied in marketing and machine decals for distinction of products of different main parameters, and can be classified as metric type and imperial type: The metric type of trade identification is applicable to machines for countries/regions using metric system or as specially required by customers; The imperial type of trade identification is applicable to the machines for countries/regions using imperial system or as specially required by customers.

# INTRODUCTION

Thank you for choosing and using the machinery of Hunan Sinoboom Intelligent Equipment Co., Ltd. Always read, understand and become familiar with the operation requirements of the machine and its associated safety procedures before operating, maintaining and repairing the machine. Operating the machine without becoming familiar with its specific operation requirements and safety procedures poses serious risks. Operators who follow safety rules and operate the machine carefully and effectively will prevent personal injury, property loss and accidents.

Use this machine only to transport tools to work locations and for performing tasks on the work platform. Operators must be competent and must obtain training to carefully use the machine and follow safety procedures. Only trained and authorized personnel may operate the machine.

This manual guides the operator and authorized personnel in maintaining the machine. The operator is responsible for reading, understanding and implementing the maintenance and safety procedures in this manual and for following the manufacturer's instructions before beginning any work. Read, understand and follow all safety rules and operating instructions. The operator must also consider the machine's uses and limitations and the conditions at the jobsite before using this machine. Strictly following all safety requirements in this manual is critical.

Consider this manual a part of the machine, along with *Operation Manual* and *Parts Manual*, and always keep the manuals with the machine. The owner or administrator of the machine shall offer all manuals and other necessary information provided by the machine manufacturer regarding the daily inspection and maintenance to each of the renters. If the machine is sold, the owner or administrator must pass along the manuals and other necessary information to the purchaser. The owner or administrator of the machine shall also provide the manufacturer's maintenance information to the person responsible for maintaining the machine.

If you have any questions, contact Hunan Sinoboom Intelligent Equipment Co., Ltd..

# 1 SPECIFICATIONS

## MACHINE SPECIFICATIONS

Table 1-1 GTJZ0408S Specifications

MEASURE	GTJZ0408S (METRIC)	1530S(IMPERIAL)
<b>DIMENSION</b>		
Max. platform height (indoor only)	4.6m	15ft 1in.
Max. working height (indoor only)	6.6m	21ft 8in.
Max. horizontal extension	0.9m	3ft
Length	1.78m	5ft 10.1in.
Width	0.76m	2ft 6in.
Height (stowed, rails folded)	1.84m	6ft 0.4in.
Height (stowed, rails up)	2.1m	6ft 10.7in.
Wheel base	1.325m	4ft 4.2in.
Wheel span	0.65m	2.14ft
Ground clearance (pothole guards retracted)	70mm	28in.
Ground clearance (pothole guards deployed)	24mm	0.95in.
Tire size (diameter × width / type)	Φ305×115mm/Solid	Φ12×4.5in./Solid
Platform dimension (Length × Width × height)	1.64m×0.76m×1.1m	5ft 4.6in.×2ft 6in.×3ft 7in.
<b>PERFORMANCE</b>		
Rated platform capacity (indoor only)	280kg	617 lb
Max capacity of extension platform(indoor only)	120kg	265 lb
Max. platform occupancy(indoor only)	2 person	
Drive speed (stowed)	0 ~ 3 km/h	0 ~ 1.86 mph
Drive speed (raised)	0 ~ 0.8 km/h	0 ~ 0.5 mph
Uptime (in a no-load state)	15 ~ 20 s	
Downtime (in a no-load state)	28 ~ 33 s	
Gradeability	30%	
Max. allowable inclination	3°(Front to back)/1.5°(Left to right)	
Turning radius (inside)	0m	0 ft

MEASURE	GTJZ0408S (METRIC)	1530S(IMPERIAL)
Turning radius (outside)	1.49m	4ft 10.7in.
Max. allowable manual force (indoor only)	400N	90 lbf
Max. noise	72dB	
<b>POWER</b>		
Hydraulic tank capacity	14L	3.1 gal(imperial)/3.7 gal(US)
Hydraulic system capacity (including tank)	14L	3.1 gal(imperial)/3.7 gal(US)
Hydraulic system pressure	24MPa	3481 psi
Battery specification (quantity × voltage, capacity)	4×6V,225Ah	
System voltage	24VDC	
Control voltage	24VDC	
<b>GROUND BEARING DATA</b>		
Max wheel load	700 kg	1543 lb
Pressure against ground	1230 KPa	178 Psi
<b>ENVIRONMENT</b>		
Max. allowable wind speed (indoor only)	0m/s	0mph
Max. allowable altitude	1000m	3280.8ft
Allowable ambient temperature (lead-acid batteries)	-10°C to 40°C	14°F to 104°F
Allowable ambient temperature (lithium batteries)	-20°C to 40°C	-4°F to 104°F
Max. allowable ambient relative humidity	90%	
Storage condition	Stored at -20°C to 50°C(-4°F to 122°F) in a well-ventilated environment with 90% relative humidity (20°C [68°F]), and away from rain, sun, corrosive gas and inflammable explosive.	
<b>WEIGHT</b>		
Weight (in a no-load state) (indoor only)	1330kg	2932.5 lb

**Table 1-2 GTJZ0608S Specifications**

MEASURE	GTJZ0608S (METRIC)	1930S(IMPERIAL)
<b>DIMENSION</b>		
Max. platform height(indoor only)	5.8m	19ft
Max. working height(indoor only)	7.8m	25ft 7in.
Max. horizontal extension	0.9m	3ft
Length	1.78m	5ft 10.1in.
Width	0.76m	2ft 6in.

MEASURE	GTJZ0608S (METRIC)	1930S(IMPERIAL)
Height (stowed, rails folded)	1.86m	6ft 1.2in.
Height (stowed, rails up)	2.12m	6ft 11.5in.
Wheel base	1.325m	4ft 4.2in.
Wheel span	0.65m	2.14ft
Ground clearance (pothole guards retracted)	70mm	28in.
Ground clearance (pothole guards deployed)	24mm	0.95in.
Tire size (diameter × width / type)	Φ305×115mm/Solid	Φ12×4.5in./Solid
Platform dimension (Length × Width × height)	1.64m×0.76m×1.1m	5ft 4.6in.×2ft 6in.×3ft 7in.
PERFORMANCE		
Rated platform capacity(indoor only)	230kg	507 lb
Max capability of extension platform(indoor only)	120kg	265 lb
Max. platform occupancy(indoor only)	2 person	
Drive speed (stowed)	0 ~ 3 km/h	0 ~ 1.86 mph
Drive speed (raised)	0 ~ 0.8 km/h	0 ~ 0.5 mph
Uptime (in a no-load state)	15 ~ 20 s	
Downtime (in a no-load state)	25 ~ 30 s	
Gradeability	25%	
Max. allowable inclination	3°(Front to back)/1.5°(Left to right)	
Turning radius (inside)	0m	0 ft
Turning radius (outside)	1.49m	4ft 10.7in.
Max. allowable manual force (indoor only)	400N	90 lbf
Max. noise	72dB	
POWER		
Hydraulic tank capacity	14L	3.1 gal(imperial)/3.7 gal(US)
Hydraulic system capacity (including tank)	14L	3.1 gal(imperial)/3.7 gal(US)
Hydraulic system pressure	24MPa	3481 psi
Battery specification (quantity × voltage, capacity)	4×6V,225Ah	
System voltage	24VDC	
Control voltage	24VDC	
GROUND BEARING DATA		
Max wheel load	700 kg	1543 lb

MEASURE	GTJZ0608S (METRIC)	1930S(IMPERIAL)
Pressure against ground	1230 KPa	178 Psi
<b>ENVIRONMENT</b>		
Max. allowable wind speed (indoor only)	0m/s	0mph
Max. allowable altitude	1000m	3280.8ft
Allowable ambient temperature (lead-acid batteries)	-10°C to 40°C	14°F to 104°F
Allowable ambient temperature (lithium batteries)	-20°C to 40°C	-4°F to 104°F
Max. allowable ambient relative humidity	90%	
Storage condition	Stored at -20°C to 50°C(-4°F to 122°F) in a well-ventilated environment with 90% relative humidity (20°C [68°F]), and away from rain, sun, corrosive gas and inflammable explosive.	
<b>WEIGHT</b>		
Weight (in a no-load state) (indoor only)	1526kg	3365 lb

**Table 1-3 GTJZ0408M Specifications**

MEASURE	GTJZ0408M (METRIC)	1532M(IMPERIAL)
<b>DIMENSION</b>		
Max. platform height	4.6m	15ft 1in.
Max. working height	6.6m	21ft 8in.
Max. horizontal extension	0.9m	3ft
Length	1.78m	5ft 10.1in.
Width	0.81m	2ft 8in.
Height (stowed, rails folded)	1.84m	6ft 0.4in.
Height (stowed, rails up)	2.1m	6ft 10.7in.
Wheel base	1.325m	4ft 4.2in.
Wheel span	0.695m	2.28ft
Ground clearance (pothole guards retracted)	70mm	28in.
Ground clearance (pothole guards deployed)	24mm	0.95in.
Tire size (diameter × width / type)	Φ305×115mm/Solid	Φ12×4.5in./Solid
Platform dimension (Length × Width × height)	1.64m×0.76m×1.1m	5ft 4.6in.×2ft 6in.×3ft 7in.
<b>PERFORMANCE</b>		
Rated platform capacity(indoor only)	280kg	617 lb
Max capability of extension platform	120kg	265 lb



MEASURE	GTJZ0408M (METRIC)	1532M(IMPERIAL)
Max. platform occupancy (indoor/outdoor)	2 person(indoor)/1 person(outdoor)	
Drive speed (stowed)	0 ~ 3 km/h	0 ~ 1.86 mph
Drive speed (raised)	0 ~ 0.8 km/h	0 ~ 0.5 mph
Uptime (in a no-load state)	15 ~ 20 s	
Downtime (in a no-load state)	28 ~ 33 s	
Gradeability	30%	
Max. allowable inclination	3°(Front to back)/1.5°(Left to right)	
Turning radius (inside)	0m	0 ft
Turning radius (outside)	1.49m	4ft 10.7in.
Max. allowable manual force (indoor/ outdoor)	400N(indoor)/200N(outdoor)	90 lbf(indoor)/45 lbf(outdoor)
Max. noise	72dB	
<b>POWER</b>		
Hydraulic tank capacity	14L	3.1 gal(imperial)/3.7 gal(US)
Hydraulic system capacity (including tank)	14L	3.1 gal(imperial)/3.7 gal(US)
Hydraulic system pressure	24MPa	3481 psi
Battery specification (quantity × voltage, capacity)	4×6V,225Ah	
System voltage	24VDC	
Control voltage	24VDC	
<b>GROUND BEARING DATA</b>		
Max wheel load	700 kg	1543 lb
Pressure against ground	1230 KPa	178 Psi
<b>ENVIRONMENT</b>		
Max. allowable wind speed (indoor/ outdoor)	0m/s(indoor)/12.5m/s(outdoor)	0 mph(indoor)/28 mph(outdoor)
Max. allowable altitude	1000m	3280.8ft
Allowable ambient temperature (lead-acid batteries)	-10°C to 40°C	14°F to 104°F
Allowable ambient temperature (lithium batteries)	-20°C to 40°C	-4°F to 104°F
Max. allowable ambient relative humidity	90%	
Storage condition	Stored at -20°C to 50°C(-4°F to 122°F) in a well-ventilated environment with 90% relative humidity (20°C [68°F]), and away from rain, sun, corrosive gas and inflammable explosive.	

MEASURE	GTJZ0408M (METRIC)	1532M(IMPERIAL)
<b>WEIGHT</b>		
Weight (in a no-load state) (indoor/ outdoor)	1330kg	2932.5 lb

**Table 1-4 GTJZ0608M Specifications**

MEASURE		GTJZ0608M (METRIC)	1932M(IMPERIAL)	
<b>DIMENSION</b>				
Max. platform height		5.8m	19ft	
Max. working height		7.8m	25ft 7in.	
Max. horizontal extension		0.9m	3ft	
Overall length-stowed	Fold-down platform	Rails down	1.78m	5ft 10in
		Rails up	1.78m	5ft 10in
	Quick fold-down platform	Rails down	1.88m	6ft 2in
		Rails up	1.78m	5ft 10in
Overall width-stowed		0.81m	2 ft 8in	
Overall height-stowed	Fold-down platform	Rails down	1.86m	6ft 1in
		Rails up-AS models	1.98m	6ft 6 in
		Rails up	2.12m	6ft 11.5in
	Quick fold-down platform	Rails down	1.95m	6ft 5in
Rails up		2.12m	6ft 11.5in	
Wheel base		1.325m	4ft 4.2in.	
Wheel span		0.695m	2.28ft	
Ground clearance (pothole guards retracted)		70mm	2.8in.	
Ground clearance (pothole guards deployed)		24mm	0.95in.	
Tire size (diameter × width / type)		Φ305×115mm/Solid	Φ12×4.5in./Solid	
Platform dimension (Length × Width × height)		1.64m×0.76m×1.1m	5ft 4.6in.×2ft 6in.×3ft 7in.	
Platform dimension (AS models)		2.34m×0.8m×0.96m	7ft 6.5in×2ft 7.5in×3ft 1.8in	
<b>PERFORMANCE</b>				
Rated platform capacity		230kg	507 lb	
Max capability of extension platform		120kg	265 lb	
Max. platform occupancy (indoor/outdoor)		2 person(indoor)/1 person(outdoor)		
Drive speed (stowed)		0 ~ 3 km/h	0 ~ 1.86 mph	
Drive speed (raised)		0 ~ 0.8 km/h	0 ~ 0.5 mph	
Uptime (in a no-load state)		15 ~ 20 s		

MEASURE	GTJZ0608M (METRIC)	1932M(IMPERIAL)
Downtime (in a no-load state)	25 ~ 30 s	
Gradeability	25%	
Max. allowable inclination	3°(Front to back)/1.5°(Left to right)	
Turning radius (inside)	0m	0 ft
Turning radius (outside)	1.49m	4ft 10.7in.
Max. allowable manual force (indoor/outdoor)	400N(indoor)/200N(outdoor)	90 lbf(indoor)/45 lbf(outdoor)
Max. noise	72dB	
<b>POWER</b>		
Hydraulic tank capacity	14L	3.1 gal(imperial)/3.7 gal(US)
Hydraulic system capacity (including tank)	14L	3.1 gal(imperial)/3.7 gal(US)
Hydraulic system pressure	24MPa	3481 psi
Battery specification (quantity × voltage, capacity)	4×6V,225Ah	
System voltage	24VDC	
Control voltage	24VDC	
<b>GROUND BEARING DATA</b>		
Max wheel load	700 kg	1543 lb
Pressure against ground	1230 KPa	178 Psi
<b>ENVIRONMENT</b>		
Max. allowable wind speed (indoor/outdoor)	0m/s(indoor)/12.5m/s (outdoor)	0 mph(indoor)/28 mph (outdoor)
Max. allowable altitude	1000m	3280.8ft
Allowable ambient temperature (lead-acid batteries)	-10°C to 40°C	14°F to 104°F
Allowable ambient temperature (lithium batteries)	-20°C to 40°C	-4°F to 104°F
Max. allowable ambient relative humidity	90%	
Storage condition	Stored at -20°C to 50°C(-4°F to 122°F) in a well-ventilated environment with 90% relative humidity (20°C [68°F]), and away from rain, sun, corrosive gas and inflammable explosive.	
<b>WEIGHT</b>		
Weight (in a no-load state) (indoor/outdoor)	1526kg	3365 lb

**NOTE:**

- a) The working height adds 2m (6ft 7in) of human height to platform height.
- b) In different areas, hydraulic oil, engine oil, coolant, fuel and lubrication should be added in accordance with the environmental temperature.
- c) In cold weather, auxiliary devices are needed to start the machines.
- d) The ground bearing data is approximate values not considering different options and only used when it is safe enough.
- e) The loads of persons, accessories, tools and materials are factored into the rated platform capacity.

POWER SYSTEM SPECIFICATIONS

Table 1-5

MEASURE	SPECIFICATIONS
<b>HYDRAULIC OIL</b>	
Normal temperature region (32°F ~ 104°F [0°C ~ 40°C])	L-HM46
Cold region (-13°F ~ 77°F [-25°C ~ 25°C])	L-HV32
Hot region (>104°F [40°C])	L-HM68
Extremely cold region (<-22°F [-30°C])	Special scheme to be determined
<b>HYDRAULIC PUMPS</b>	
Type	Gear pump
Flow rate (RPM = 3000 r/min)	12 L/min
Maximum driving pressure	31MPa ( 4495Psi)
<b>DRIVE HYDRAULIC MOTOR</b>	
Type	Gerotor motor
Displacement	300cc/r
<b>FUNCTIONAL VALVES</b>	
Lift relief valve pressure	21MPa (3045Psi)
Steer relief valve pressure	12MPa (1740Psi)
<b>HYDRAULIC RETURN FILTER</b>	
Bypass pressure	0.17MPa ( 24.56Psi)

**NOTICE**

*Different hydraulic oils can be added according to customer requirements upon factory delivery, but cannot be mixed.*

## HYDRAULIC HOSE AND FITTING SPECIFICATIONS

### HYDRAULIC HOSE TORQUE

Hydraulic hoses must be torqued to the following specifications.

**Table 1-6 Hydraulic Hose Torque**

METRIC THREAD	L (LIGHT-DUTY)	S (HEAVY-DUTY)
M12 × 1.5	19 ± 1 Nm (14 ± 1 ft-lb)	
M14 × 1.5	26 ± 2 Nm (19 ± 2 ft-lb)	
M16 × 1.5	40 ± 3 Nm (30 ± 2 ft-lb)	
M18 × 1.5	50 ± 4 Nm (37 ± 3 ft-lb)	
M20 × 1.5	-	60 ± 4 Nm (44 ± 3 ft-lb)
M22 × 1.5	70 ± 5 Nm (52 ± 4 ft-lb)	-
M24 × 1.5	-	85 ± 6 Nm (63 ± 4 ft-lb)
M26 × 1.5	90 ± 6 Nm (66 ± 4 ft-lb)	-
M30 × 2	120 ± 8 Nm (89 ± 6 ft-lb)	140 ± 10 Nm (103 ± 7 ft-lb)
M36 × 2	150 ± 12 Nm (111 ± 9 ft-lb)	180 ± 12 Nm (133 ± 9 ft-lb)
M42 × 2	-	260 ± 16 Nm (192 ± 12 ft-lb)
M45 × 2	240 ± 15 Nm (177 ± 11 ft-lb)	-
M52 × 2	250 ± 16 Nm (184 ± 12 ft-lb)	280 ± 18 Nm (207 ± 13 ft-lb)

### HYDRAULIC FITTING TORQUE

Hydraulic fittings with metric thread must be torqued to the following specifications.

**Table 1-7 Hydraulic Fitting Torque – Metric**

THREAD SIZE	INSTALLED INTO ALUMINUM	INSTALLED INTO STEEL	
	ED, O-RING + CIRCLIP	ED, O-RING + CIRCLIP	O-RING
<b>L (LIGHT-DUTY)</b>			
M10×1	18 ± 1 Nm (13 ± 1 ft-lb)	20 ± 2 Nm (15 ± 2 ft-lb)	18 ± 1 Nm (13 ± 1 ft-lb)
M12×1.5	30 ± 2 Nm (22 ± 2 ft-lb)	35 ± 2 Nm (26 ± 2 ft-lb)	30 ± 2 Nm (22 ± 2 ft-lb)
M14×1.5	42 ± 3 Nm (31 ± 2 ft-lb)	48 ± 4 Nm (35 ± 3 ft-lb)	35 ± 2 Nm (26 ± 2 ft-lb)
M16×1.5	55 ± 4 Nm (41 ± 3 ft-lb)	60 ± 4 Nm (44 ± 3 ft-lb)	40 ± 3 Nm (30 ± 3 ft-lb)

THREAD SIZE	INSTALLED INTO ALUMINUM	INSTALLED INTO STEEL	
	ED, O-RING + CIRCLIP	ED, O-RING + CIRCLIP	O-RING
M18×1.5	75 ± 5 Nm (55 ± 4 ft-lb)	75 ± 5 Nm (55 ± 4 ft-lb)	45 ± 3 Nm (33 ± 4 ft-lb)
M22×1.5	90 ± 6 Nm (66 ± 4 ft-lb)	130 ± 8 Nm (96 ± 6 ft-lb)	60 ± 4 Nm(44 ± 3 ft-lb )
M27×2	120 ± 8 Nm (89 ± 6 ft-lb)	185 ± 12 Nm (136 ± 9 ft-lb)	100 ± 7 Nm (74 ± 5 ft-lb)
M30×2	140 ± 8 Nm (103 ± 6 ft-lb)	245 ± 15 Nm (181 ± 11 ft-lb)	135 ± 8 Nm (100 ± 6 ft-lb)
M33×2	180 ± 10 Nm (133 ± 7 ft-lb)	320 ± 20 Nm (236 ± 15 ft-lb)	160 ± 10 Nm(118 ± 7 ft-lb )
M42×2	240 ± 15 Nm (177 ± 11 ft-lb)	450 ± 25 Nm (332 ± 18 ft-lb)	210 ± 13 Nm (155 ± 10 ft-lb)
M48×2	280 ± 20 Nm (207 ± 15 ft-lb)	540 ± 30 Nm (398 ± 22 ft-lb)	260 ± 15 Nm (192 ± 11 ft-lb)
<b>S (HEAVY-DUTY)</b>			
M12×1.5	33 ± 2 Nm (24 ± 2 ft-lb)	43 ± 3 Nm (32 ± 2 ft-lb)	35 ± 2 Nm (26 ± 2 ft-lb)
M14×1.5	42 ± 3 Nm (31 ± 2 ft-lb)	50 ± 4 Nm (37 ± 3 ft-lb)	45 ± 3 Nm (33 ± 2 ft-lb)
M16×1.5	55 ± 4 Nm (41 ± 3 ft-lb)	75 ± 5 Nm (55 ± 4 ft-lb)	55 ± 4 Nm (41 ± 3 ft-lb)
M18×1.5	75 ± 5 Nm (55 ± 4 ft-lb)	95 ± 6 Nm (70 ± 4 ft-lb)	70 ± 5 Nm (52 ± 4 ft-lb)
M22×1.5	90 ± 6 Nm (66 ± 4 ft-lb)	140 ± 8 Nm(103 ± 6 ft-lb )	100 ± 10 Nm (74 ± 7 ft-lb)
M27×2	120 ± 8 Nm (89 ± 6 ft-lb)	185 ± 12 Nm (136 ± 9 ft-lb)	160 ± 10 Nm (118 ± 7 ft-lb)
M30×2	140 ± 8 Nm (103 ± 6 ft-lb)	245 ± 15 Nm (181 ± 11 ft-lb)	210 ± 13 Nm (155 ± 10 ft-lb)
M33×2	180 ± 10 Nm (133 ± 7 ft-lb)	320 ± 20 Nm (236 ± 15 ft-lb)	260 ± 15 Nm (192 ± 11 ft-lb)
M42×2	240 ± 15 Nm (177 ± 11 ft-lb)	450 ± 25 Nm (332 ± 18 ft-lb)	330 ± 20 Nm (243 ± 15 ft-lb)
M48×2	280 ± 20 Nm (207 ± 15 ft-lb)	540 ± 30 Nm (398 ± 22 ft-lb)	420 ± 25 Nm (310 ± 18 ft-lb)

Hydraulic fittings with inch thread (British Standard Pipe [BSP]) must be torqued to the following specifications.

**Table 1-8 Hydraulic Fitting Torque – British Standard Pipe (BSP)**

THREAD SIZE	INSTALLED INTO ALUMINUM	INSTALLED INTO STEEL	
	ED, O-RING + CIRCLIP	ED, O-RING + CIRCLIP	O-RING
<b>L (LIGHT-DUTY)</b>			
G1/8A	20 ± 1 Nm (15 ± 1 ft-lb)	20 ± 1 Nm (15 ± 1 ft-lb)	-
G1/4A	35 ± 2 Nm (26 ± 2 ft-lb)	40 ± 2 Nm (30 ± 2 ft-lb)	-
G3/8A	50 ± 3 Nm (37 ± 2 ft-lb)	75 ± 5 Nm (55 ± 2 ft-lb)	-
G1/2A	75 ± 5 Nm (55 ± 2 ft-lb)	95 ± 6 Nm (70 ± 4 ft-lb)	-
G3/4A	120 ± 8 Nm (89 ± 6 ft-lb)	185 ± 12 Nm (136 ± 9 ft-lb)	-
G1A	180 ± 10 Nm (133 ± 7 ft-lb)	320 ± 20 Nm (236 ± 15 ft-lb)	-
G1-1/4A	240 ± 15 Nm (177 ± 11 ft-lb)	450 ± 25 Nm (332 ± 18 ft-lb)	-

THREAD SIZE	INSTALLED INTO ALUMINUM	INSTALLED INTO STEEL	
	ED, O-RING + CIRCLIP	ED, O-RING + CIRCLIP	O-RING
G1-1/2A	280 ± 20 Nm (207 ± 15 ft-lb)	540 ± 30 Nm (398 ± 22 ft-lb)	-
<b>S (HEAVY-DUTY)</b>			
G1/4A	40 ± 3 Nm (30 ± 2 ft-lb)	43 ± 3 Nm (32 ± 2 ft-lb)	-
G3/8A	55 ± 3 Nm (41 ± 2 ft-lb)	85 ± 5 Nm (63 ± 4 ft-lb)	-
G1/2A	80 ± 5 Nm (59 ± 4 ft-lb)	120 ± 8 Nm (89 ± 6 ft-lb)	-
G3/4A	120 ± 8 Nm (89 ± 6 ft-lb)	185 ± 12 Nm (136 ± 9 ft-lb)	-
G1A	180 ± 10 Nm (133 ± 7 ft-lb)	320 ± 20 Nm (236 ± 15 ft-lb)	-
G1-1/4A	240 ± 15 Nm (177 ± 11 ft-lb)	450 ± 25 Nm (332 ± 18 ft-lb)	-
G1-1/2A	280 ± 20 Nm (207 ± 15 ft-lb)	540 ± 30 Nm (398 ± 22 ft-lb)	-

Hydraulic fittings with Unified Thread Standard (UNC/UNF) must be torqued to the following specifications.

**Table 1-9 Hydraulic Fitting Torque – Unified Thread Standard (UNC/UNF)**

THREAD SIZE	INSTALLED INTO ALUMINUM	INSTALLED INTO STEEL
	O-RING	O-RING
<b>L (LIGHT-DUTY)</b>		
7/16-20	21 ± 2 Nm (15 ± 2 ft-lb)	21 ± 2 Nm (15 ± 2 ft-lb)
9/16-18	34 ± 2 Nm (25 ± 2 ft-lb)	35 ± 2 Nm (26 ± 2 ft-lb)
11/16-12	40 ± 3 Nm (30 ± 2 ft-lb)	50 ± 4 Nm (37 ± 3 ft-lb)
3/4-16	50 ± 3 Nm (37 ± 2 ft-lb)	65 ± 4 Nm (48 ± 3 ft-lb)
7/8-14	75 ± 5 Nm (55 ± 4 ft-lb)	110 ± 8 Nm (81 ± 6 ft-lb)
1-1/16-12	110 ± 8 Nm (81 ± 6 ft-lb)	140 ± 10 Nm (103 ± 7 ft-lb)
1-5/16-12	160 ± 10 Nm (118 ± 7 ft-lb)	210 ± 15 Nm (155 ± 11 ft-lb)
<b>S (HEAVY-DUTY)</b>		
7/16-20	21 ± 2 Nm (15 ± 2 ft-lb)	23 ± 2 Nm (17 ± 2 ft-lb)
9/16-18	34 ± 2 Nm (25 ± 2 ft-lb)	40 ± 3 Nm (30 ± 2 ft-lb)
11/16-12	40 ± 3 Nm (30 ± 2 ft-lb)	65 ± 4 Nm (48 ± 3 ft-lb)
3/4-16	50 ± 3 Nm (37 ± 2 ft-lb)	80 ± 6 Nm (59 ± 4 ft-lb)
7/8-14	75 ± 5 Nm (55 ± 4 ft-lb)	125 ± 10 Nm (92 ± 7 ft-lb)
1-1/16-12	110 ± 8 Nm (81 ± 6 ft-lb)	185 ± 15 Nm (136 ± 11 ft-lb)
1-5/16-12	160 ± 10 Nm (118 ± 7 ft-lb)	280 ± 20 Nm (207 ± 15 ft-lb)

## HYDRAULIC HOSE AND FITTING TORQUE PROCEDURE

The hydraulic hose and fitting must be torqued to the following requirements when they are installed.

1. Replace the O-ring if damaged. The O-ring cannot be reused if the fitting or hose end has been tightened beyond finger tight.
2. Lubricate the O-ring before installation.
3. Properly seat the O-ring.
4. Position the tube and nut squarely on the fitting. Then tighten the nut as required.
5. Tighten the nut or fitting to the torque specified in the appropriate table.
6. Operate all machine functions and inspect the hose, fittings and related components to confirm there are no leaks.

## FASTENER TORQUE SPECIFICATIONS

Unless special torque requirements are stated in this manual or other instructions, torque metric bolts to the values listed in the table below.

**Table 1-10 Fastener Torque Specifications – Metric**

NOMINAL DIAMETER (MM)	PITCH (MM)	CLASS 8.8	CLASS 10.9	CLASS 12.9
5	0.8	7 Nm (5 ft-lb)	9 Nm (7 ft-lb)	10 Nm (7 ft-lb)
6	1	12 Nm (9 ft-lb)	15 Nm (11 ft-lb)	18 Nm (13 ft-lb)
8	1.25	30 Nm (22 ft-lb)	35 Nm (26 ft-lb)	42 Nm (31 ft-lb)
	1	30 Nm (22 ft-lb)	37 Nm (27 ft-lb)	45 Nm (33 ft-lb)
10	1.5	55 Nm (41 ft-lb)	75 Nm (55 ft-lb)	85 Nm (63 ft-lb)
	1.25	56 Nm (41 ft-lb)	77 Nm (57 ft-lb)	87 Nm (64 ft-lb)
	1	60 Nm (44 ft-lb)	80 Nm (59 ft-lb)	92 Nm (68 ft-lb)
12	1.75	95 Nm (70 ft-lb)	125 Nm (92 ft-lb)	150 Nm (111 ft-lb)
	1.5	100 Nm (74 ft-lb)	130 Nm (96 ft-lb)	155 Nm (114 ft-lb)
	1.25	105 Nm (77 ft-lb)	135 Nm (100 ft-lb)	160 Nm (118 ft-lb)
14	2	150 Nm (110 ft-lb)	200 Nm (148 ft-lb)	230 Nm (170 ft-lb)
	1.5	165 Nm (122 ft-lb)	210 Nm (155 ft-lb)	250 Nm (184 ft-lb)
16	2	230 Nm (170 ft-lb)	300 Nm (221 ft-lb)	360 Nm (266 ft-lb)
	1.5	250 Nm (184 ft-lb)	320 Nm (236 ft-lb)	380 Nm (280 ft-lb)
18	2.5	320 Nm (236 ft-lb)	420 Nm (310 ft-lb)	500 Nm (369 ft-lb)
	1.5	360 Nm (266 ft-lb)	470 Nm (345 ft-lb)	550 Nm (406 ft-lb)
20	2.5	450 Nm (332 ft-lb)	600 Nm (443 ft-lb)	700 Nm (516 ft-lb)
	1.5	500 Nm (369 ft-lb)	650 Nm (479 ft-lb)	770 Nm (568 ft-lb)
22	2.5	600 Nm (443 ft-lb)	800 Nm (590 ft-lb)	980 Nm (723 ft-lb)
	2	650 Nm (479 ft-lb)	850 Nm (627 ft-lb)	1050 Nm (774 ft-lb)



NOMINAL DIAMETER (MM)	PITCH (MM)	CLASS 8.8	CLASS 10.9	CLASS 12.9
24	3	750 Nm (553 ft-lb)	1050 Nm (774 ft-lb)	1250 Nm (923 ft-lb)
	2	800 Nm (590 ft-lb)	1100 Nm (811 ft-lb)	1300 Nm (959 ft-lb)
27	3	1150 Nm (848 ft-lb)	1500 Nm (1106 ft-lb)	1800 Nm (1327 ft-lb)
30	3.5	1500 Nm (1106 ft-lb)	2000 Nm (1475 ft-lb)	2400 Nm (1770 ft-lb)

Unless special torque requirements are listed in this manual or other instructions, torque Unified Thread Standard bolts (label: UNC) to the values listed in the table below.

**Table 1-11 Bolt Torque Specifications Unified – Thread Standard (UNC)**

NOMINAL DIAMETER (IN)	OPPOSITE NUT SIZE (S)	CLASS 5	CLASS 8
1/4-20	7/16"	10 Nm (7 ft-lb)	14 Nm (10 ft-lb)
5/16-18	1/2"	21 Nm (15 ft-lb)	29 Nm (21 ft-lb)
3/8-16	9/16"	37 Nm (27 ft-lb)	51 Nm (38 ft-lb)
7/16-14	5/8"	60 Nm (44 ft-lb)	82 Nm (60 ft-lb)
1/2-13	3/4"	90 Nm (66 ft-lb)	130 Nm (96 ft-lb)
9/16-12	13/16"	130 Nm (96 ft-lb)	180 Nm (133 ft-lb)
5/8-11	15/16"	178 Nm (131 ft-lb)	250 Nm (184 ft-lb)
3/4-10	1-1/8"	315 Nm (232 ft-lb)	445 Nm (328 ft-lb)
7/8-9	-	509 Nm (375 ft-lb)	715 Nm (527 ft-lb)

Unless special torque requirements are listed in this manual or other instructions, torque Unified Thread Standard bolts (label: UNF) to the values listed in the table below.

**Table 1-12 Bolt Torque Specifications – Thread Standard (UNF)**

NOMINAL DIAMETER (IN)	OPPOSITE NUT SIZE (S)	CLASS 5	CLASS 8
1/4-28	7/16"	11.5 Nm (8 ft-lb)	16 Nm (11 ft-lb)
5/16-24	1/2"	23 Nm (17 ft-lb)	32 Nm (24 ft-lb)
3/8-24	9/16"	41 Nm (30 ft-lb)	58 Nm (43 ft-lb)
7/16-20	5/8"	65 Nm (48 ft-lb)	92 Nm (68 ft-lb)
1/2-20	3/4"	100 Nm (74 ft-lb)	145 Nm (107 ft-lb)
9/16-18	13/16"	145 Nm (107 ft-lb)	200 Nm (148 ft-lb)
5/8-18	15/16"	200 Nm (148 ft-lb)	280 Nm (207 ft-lb)
3/4-16	1-1/8"	350 Nm (258 ft-lb)	495 Nm (365 ft-lb)
7/8-14	-	560 Nm (413 ft-lb)	780 Nm (575 ft-lb)

# 3 SYSTEM DESCRIPTIONS

## POWER

Machines are powered by four 6V batteries in series or a 24V lithium battery to drive a 24V DC motor. Gear pump and motor output shaft is splined to provide power to the system.

## HYDRAULIC SYSTEM

All machine functions are performed by the hydraulic system, which can be divided into two parts: one part is used for driving and steering function and the other part for platform lifting function.

When the machine is activated, the hydraulic pump sends the pressure oil to the function manifold which is equipped with directional valves for performing different actions and flow regulating valves for adjusting the speed. To protect relevant components and avoid pressure overload, the function manifold is provided with a relief valve.

## ELECTRICAL SYSTEM

In the electrical system, machines are powered by four 6V batteries in series or a 24V lithium battery to drive the motor on the power unit. The battery is charged from an external power supply.

## MACHINE CONTROL SYSTEM

The functions of the machine are controlled with two controllers in this system. A controller is located on the right door of the machine and controls the platform up/down functions. The other controller is located on the platform and controls lift and drive functions. The controller exchanges data through a high-speed data bus.

## SAFETY MEASURES

A series of angle sensors and limit switches provides signals to the controllers. The level sensor measures

the angle of machine on X-axis and Y-axis. When the angle on X-axis exceeds 1.5 degrees or the angle on Y-axis exceeds 3 degrees, the alarm will be triggered, and the function of lift, drive or steer will be limited.

A pothole limit switch confirms if the pothole guards are fully deployed. When the platform rises to approximately 1.5m(4ft 11in), the pothole guards are not deployed, and the sensor has not detected the signal, the platform will stop rising.

Platform weighing system is used to detect the load capacity of the platform. When the actual platform load exceeds the rated load (see [Machine Specifications, page 1-1](#)), the platform lifting height is more than 39 in. (1 m) or 10% of the height that can be lifted(use the greater number), the overload indicator lamp will illuminate, the alarms will sound, and the platform will stop moving. To allow the platform to move again, remove the excess load until the load is less than the rated capacity.